

KINEMATIC AND DYNAMIC BEHAVIOR OF A WEARING JOINT IN A CRANK-SLIDER MECHANISM

Nathan A. Mauntler¹, Saad M. Mukras¹, Nam-Ho Kim¹, W. Gregory Sawyer¹, and Tony L. Schmitz¹

¹Department of Mechanical and Aerospace Engineering
University of Florida
Gainesville, Florida, United States

INTRODUCTION AND SCOPE

The ability to predict the behavior of components and mechanisms is central to mechanical design, often separating success from failure. In many cases, error motions in mechanical joints can have significant effects on the kinematic and dynamic behavior of the mechanism. Recent multibody dynamics modeling research highlights the effects of joint clearance, friction, and compliance on mechanism behavior [1,2].

These effects may be exacerbated as wear occurs, affecting not only the magnitude of clearance but also the shape of the joint components. Efforts to model the coupled relationship between joint geometry, contact loads, and wear have been applied to such scenarios as scotch yoke mechanisms, cam-follower joints, and simply loaded pin-bushing revolute joints [3,4]. In some cases, no experimental validation of the modeling effort is offered, while in other cases only wear is measured while load conditions are inferred.

In this work, the joint under study is a pin-bushing revolute joint between the crank and follower links of a crank-slider mechanism. The crank-slider is chosen because it provides a planar mechanism for which kinematic and dynamic solutions are available for both idealized and realistic joint scenarios. Additionally, this mechanism has relevance to the automotive, aerospace, and heavy equipment industries. Procedures for modeling the coupled evolution of wear and dynamics for this scenario have been described by Mukras *et al* [5].

The experimental goals of this project are to:

- 1) Design and build an instrumented crank-slider test bed in order to characterize the dynamic and error motion contributions of a single wearing joint in dry sliding;

- 2) Provide a library of experimental data available for comparison with dynamic and wear models.

EXPERIMENTAL APPARATUS

The crank-slider test bed (*FIGURE 1*) is designed to isolate friction, wear, and error motions to the joint of interest in order to study the joint directly, while minimizing confounding influences from the rest of the mechanism. While the pin-bushing joint is instrumented to measure dynamic and kinematic behavior and allowed to wear, the remainder of the mechanism is intended to provide idealized mechanical behavior.

The kinematic components of the test bed can be thought of as belonging to one of two categories: those intended to supply a constant rotational crank speed and those intended to allow free motion of the slide. Motion-generating components include a DC motor, gear reducer, timing belt, flywheel (used to enable constant angular velocity in the presence of disturbances; not shown), block spindle, and aluminum crank link. The crank link has a length of 76.2 mm (3 in.) while the follower link has a length of 203.2 mm (8 in.).

The pin at the joint of interest is clamped at one end in the crank arm and is free to rotate, subject to sliding friction, within a wearing test bushing. The wear bushing is clamped in the follower link. In order to provide low friction, high joint stiffness, and minimal joint wear, the follower link and slider stage are joined by two porous carbon thrust air bushings. Similarly, the dovetail slide itself is constructed of porous carbon air bearings. Wearing test bushings are machined from virgin electrical grade polytetrafluoroethylene (PTFE).

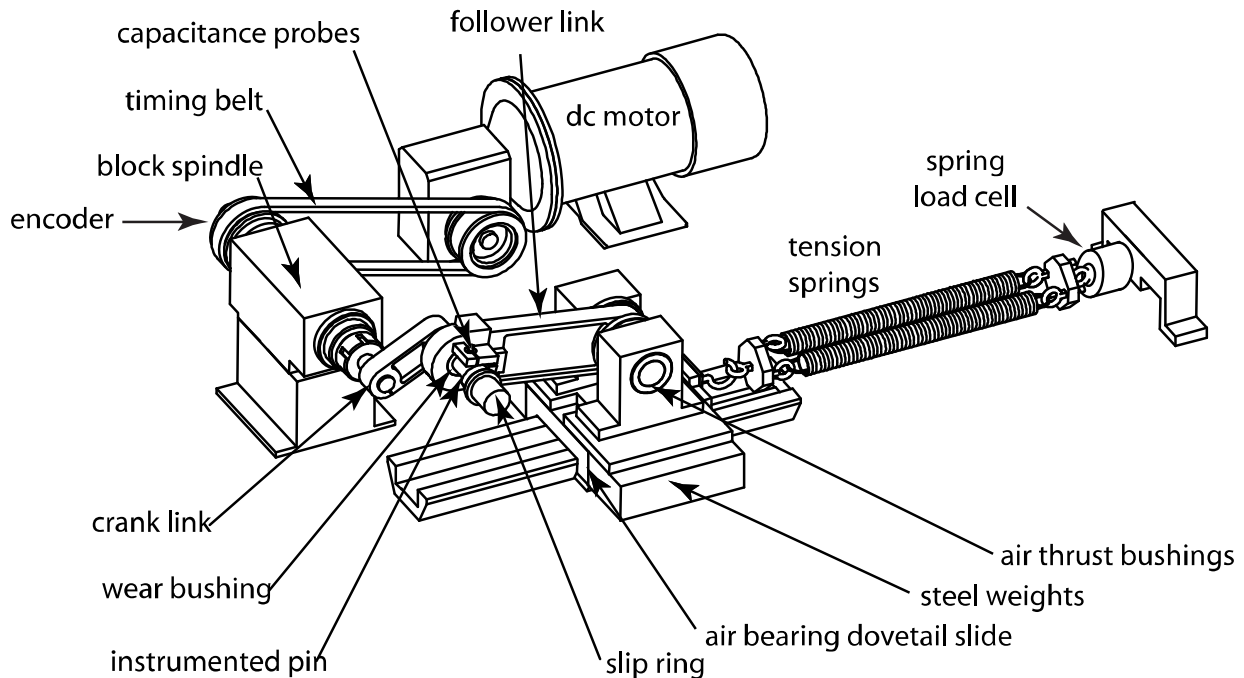

FIGURE 1. The instrumented crank-slider test bed.

The cyclic load profile at the joint under study can be manipulated in several ways. First, the mechanism inertia can be increased by adding up to 8.6 kg of steel weights to the slide stage. Second, coil tension springs can be added in parallel between the slide and the table on which the mechanism is mounted. Of course, the influence of the mechanism dynamics on the system behavior can be modified by varying the crank speed as well.

Pin forces at the joint of interest are measured using a strain gauge load cell (FIGURE 2). This load cell is composed of two full-bridge strain gauges arrays offset by 90 deg. The gauges of each bridge are arranged to measure transverse shear in a single direction while canceling the effects of axial, bending, and torsion strains. This pin is hollowed to increase strains and the gauged portion of the pin is necked to localize strains to that area. One bridge measures loads parallel to the crank radial direction, while the other measures loads parallel to the crank circumferential direction. Signals are transmitted from the strain gauges to data acquisition hardware through a 10-circuit slip ring.

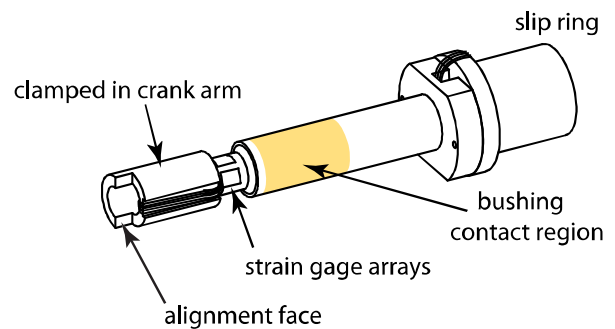

FIGURE 2. Strain gauge load cell built onto the pin at the joint of interest.

In-plane translational error motions are measured using two orthogonal capacitance probes mounted to the follower link (FIGURE 3). These probes indicate the position of the pin center with respect to the bushing center and provide a means to track the evolution of in-plane errors as bushing wear occurs.

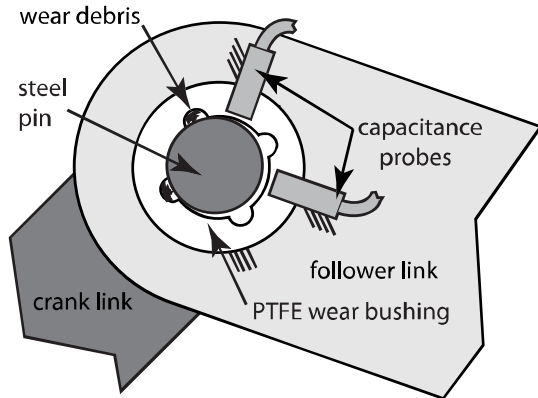

FIGURE 3. Capacitance probes used to measure the location of the pin with respect to the bushing center.

Typically, the purpose of a crank-slider mechanism is to accurately prescribe reciprocating motion of the slide due to rotation of the crank. For that reason, the position of the stage is recorded using a displacement measuring interferometer (FIGURE 4). In this setup, light emitted from the two-frequency head is split into two paths: a fixed reference path and the measurement path defined by a target retroreflector mounted on the sliding stage. The two light signals are then recombined and the interference between them is used to quantify the stage displacement.

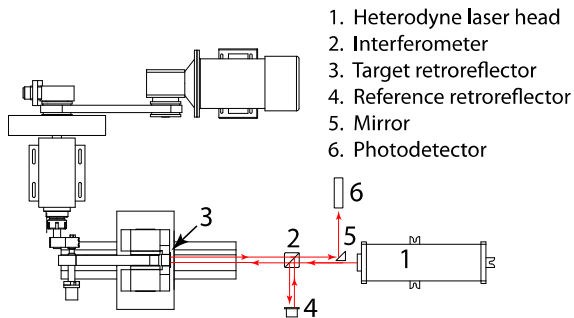

FIGURE 4. A linear displacement measuring interferometer is used to track motion of the stage.

Since the crank-slider behavior is periodic, it is often useful to plot force and displacement data with respect to the crank angle. For this reason, the angular location of the crank link is measured using a 3600 count-per-revolution hollow shaft encoder clamped to the spindle axis. The crank angle θ is measured counterclockwise from horizontal as shown in FIGURE 5.

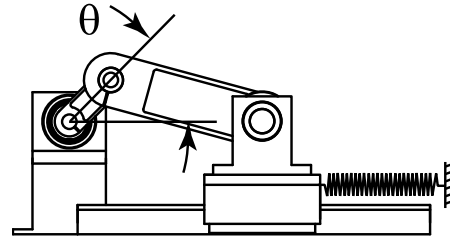

FIGURE 5. Definition of the crank angle θ .

COUPLED EVOLUTION OF WEAR AND DYNAMICS

In order to investigate the coupled nature of joint geometry and dynamics, a wear test was conducted using the conditions listed in TABLE 1. As the bushing wore over the course of the test, high frequency dynamics were seen to develop in the cyclic force profile (FIGURE 6). This content is associated with vibration of the bushing relative to the pin as the contact location shifted in direction. Similar vibration was observed in the capacitance probe and interferometer measurements (FIGURE 7).

TABLE 1. Wear test operating conditions

Initial bushing diameter (mm)	19.066
Initial bushing roundness error (μm)	22
Initial bushing mass (g)	13.1566
Crank speed (rpm)	30
Stage mass (kg)	8.5
Cycles completed	420,000

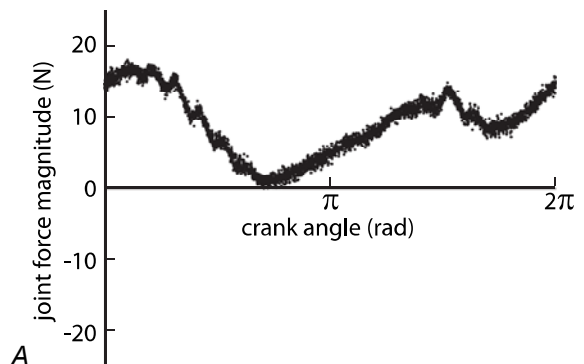

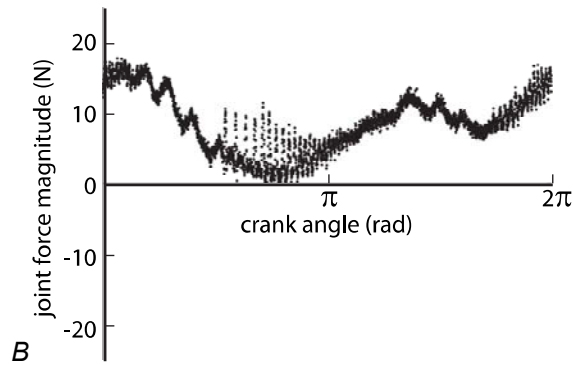

FIGURE 6. Single cycle joint force magnitude profiles at cycle 10 (A) and cycle 419,000 (B) show the evolution of high frequency vibration as the bushing wore.

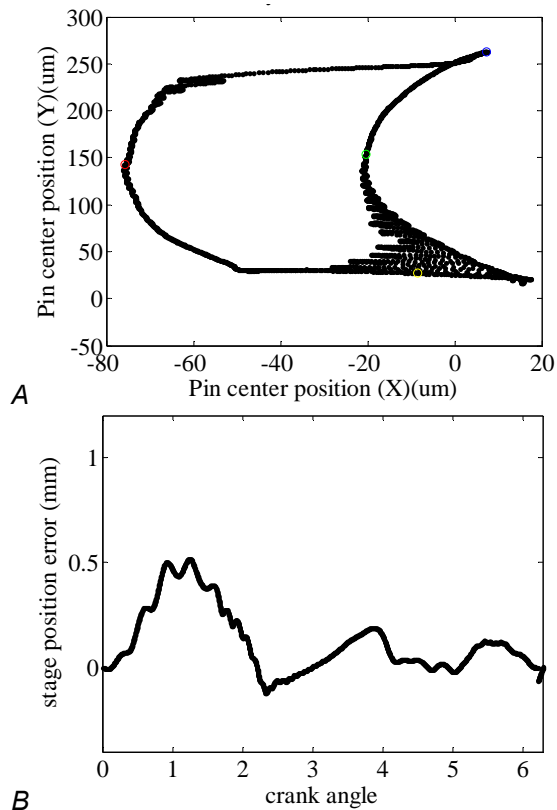

FIGURE 7. Capacitance probe measurements (A) and stage error motions measured by the interferometer (B) from cycle 419,000 also indicate the presence of high frequency vibration. The stage position error was obtained by subtracting the predicted gross motion from the measured stage position.

ACKNOWLEDGEMENTS

This work is supported by the National Science Foundation and John Deere under NSF GOALI

grant #CMMI-0600375. Any opinion or findings expressed in this material are those of the authors and do not necessarily reflect the views of the National Science Foundation or Deere & Company. Furthermore, the authors would like to acknowledge the support of Agilent Technologies for providing interferometry hardware and software used in this study.

REFERENCES

- [1] Ravn P. A Continuous Analysis Method for Planar Multibody Systems with Joint Clearance. *Multibody System Dynamics*. 1998, 2: 1-24.
- [2] Flores A, Ambrosio J. Revolute Joints with Clearance in Multibody Systems. *Computers and Structures*. 2004, 82:1359-1369.
- [3] Blanchet T. The Interaction of Wear and Dynamics of a Simple Mechanism. *Journal of Tribology*. 1997, 119:597-599.
- [4] Dickrell D, Dooner D, Sawyer W. The Evolution of Geometry for a Wearing Circular Cam: Analytical and Computer Simulation With Comparison to Equipment. *Journal of Tribology*. 2003, 125: 187-192.
- [5] Mukras S, Kim N-H, Sawyer W, Jackson D, Bergquist L. Numerical Integration Schemes and Parallel Computation for Wear Prediction Using Finite Element Method. *Wear*. 2009, 266: 822-831.